



## OPERATING INSTRUCTIONS FOR THE RDX-6 DIPLEXER

The RDX-6 Diplexer is a passive device for use in pulsed ultrasonic systems employing a single transmit/receive transducer (“Pulse Echo” operation). The unit features a unique transformer/diode arrangement to deliver high power pulses to a transducer while return signals from the same transducer are transferred to a receiver. In the process, the receiver is protected from overdrive, and a fast recovery is provided.

Because the process of diplexing is never perfect, additional items have been added to the RDX-6. The first of these is a set of seven switch selectable inductors in parallel with the primary winding of the diplexing transformer, which is shown as T1 on the attached schematic. The purpose of these inductors is to destroy the low frequency response of the transformer, when acceptable, rejecting low frequency artifacts that may occur. This will result in further improvement in recovery time of the system. Poor recovery time is generally a result of baseline distortion in the transmitted pulse when driving a highly reactive load such as a piezoelectric transducer. The second item is a set of eight switch selectable resistors across the secondary winding of the diplexing transformer, T1. These can be of value in improving the resolution of signals, if the first stage of the receiving system has a high impedance input; they aid in damping out ringing of the transducer. The third item is a switch selectable Diode Expander at the input of the unit. (All diodes are fast switching silicon devices with a threshold of 0.7V.) They remove 0.7 V of the driving signal from either side of the baseline, and they also block any leakage, including noise, from the transmitter from appearing at the receiver input. The fourth item is a pair of switch selectable attenuators (1 dB and 2 dB) which can be switched into the transmit/receive system to serve as a low impedance reference for the transmitter end of the transformer. The attenuators also aid in improving the quality of the driving pulse when a highly reactive load such as a ceramic piezoelectric transducer is used. One of these attenuators should be switched into the system whenever the diode expander is used; the resistors in the attenuator provide a return path to ground for any DC signal that may result from the stray capacity of the diode expanders. The attenuators are limited to an average power dissipation of 5W or 0.1% duty cycle (percent “on” time) with an input burst of 1440V peak-to-peak or 5KW.

To use this diplexer, connect the “IN” connector on the RDX-6 to the “High Voltage RF PULSE OUTPUT” connector on the pulse source using a short BNC cable. Connect the “OUT” connector on the RDX-6 to an appropriate transducer and connect the “TO REC.” connector to the input of the receiver.

The frequency range of the RDX-6 diplexer extends from approximately 250 kHz to above 40 MHz. The amplitude of the return signals, to be sent to a receiver, will depend on the output impedance of the pulsing system and the selection of the two attenuators. If the pulsing system has a high impedance during the “off” time, then the amplitude of the return signals can be improved by switching in either the 1 or 2 dB attenuators. Adjustment of the various switch selectable items is usually carried out on a trial-and-error basis for the best overall performance of the pulser/receiver system.

Rotating the “DAMPING” switch in a clockwise direction from Position 1 to Position 8 increases the damping of the signal by decreasing the value of the damping resistor across the primary winding of the diplexing transformer from a maximum of 1300 Ohms to a minimum of 10 Ohms.

<b>Position</b>	<b>Damping Resistor</b>
1	1300 Ohms
2	619 Ohms
3	310 Ohms
4	162 Ohms
5	80 Ohms
6	41 Ohms
7	22 Ohms
8	10 Ohms

Rotating the “LOW FREQ. CUT” switch in a clockwise direction from Position A to Position H increases the low frequency cutoff of the diplexer. Adjustments are normally made on a trial-and-error basis for the best overall operation. The approximate 3 dB points for the low frequency cut-off are provided below, assuming the diplexer is connected to a 50 Ohm load.

<b>Position</b>	<b>Inductance</b>	<b>Approx. 3 dB point</b>
A	Open	30 kHz
B	27 $\mu$ H	275 kHz
C	10 $\mu$ H	750 kHz
D	4.7 $\mu$ H	1.6 MHz
E	2.2 $\mu$ H	3.4 MHz
F	1 $\mu$ H	7.5 MHz
G	0.47 $\mu$ H	16 MHz
H	0.22 $\mu$ H	34 MHz

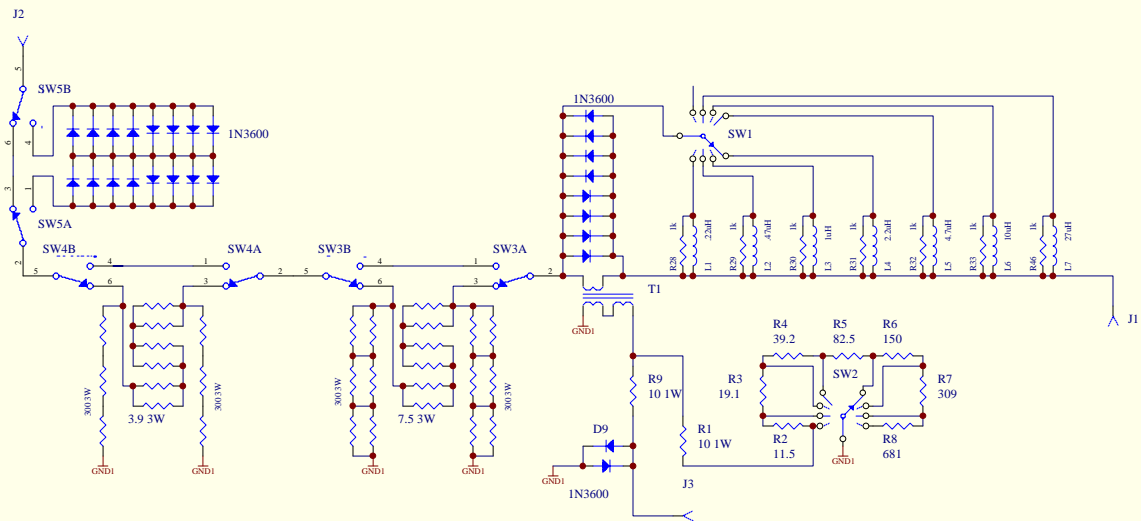

Title			<b>DIPLEXER</b>		
Size	Number	Revision			
A3	<b>RDX-6</b>				
Date:	9-Sep-1996	Sheet of			
File:	C:\PROTEL\RD\47501	Drawn By:			